

ISSUE	DATE	CHANGE	APPROVAL	ZONE
A	06/07/2011	INITIAL RELEASE		
B	28/7/11	CHANGE PART 21-MPMD833 TO 21-MPMD362, ADD WASHERS	CL	
C	8/09/11	PART NO. UPDATED, BOM UPDATED	CL	

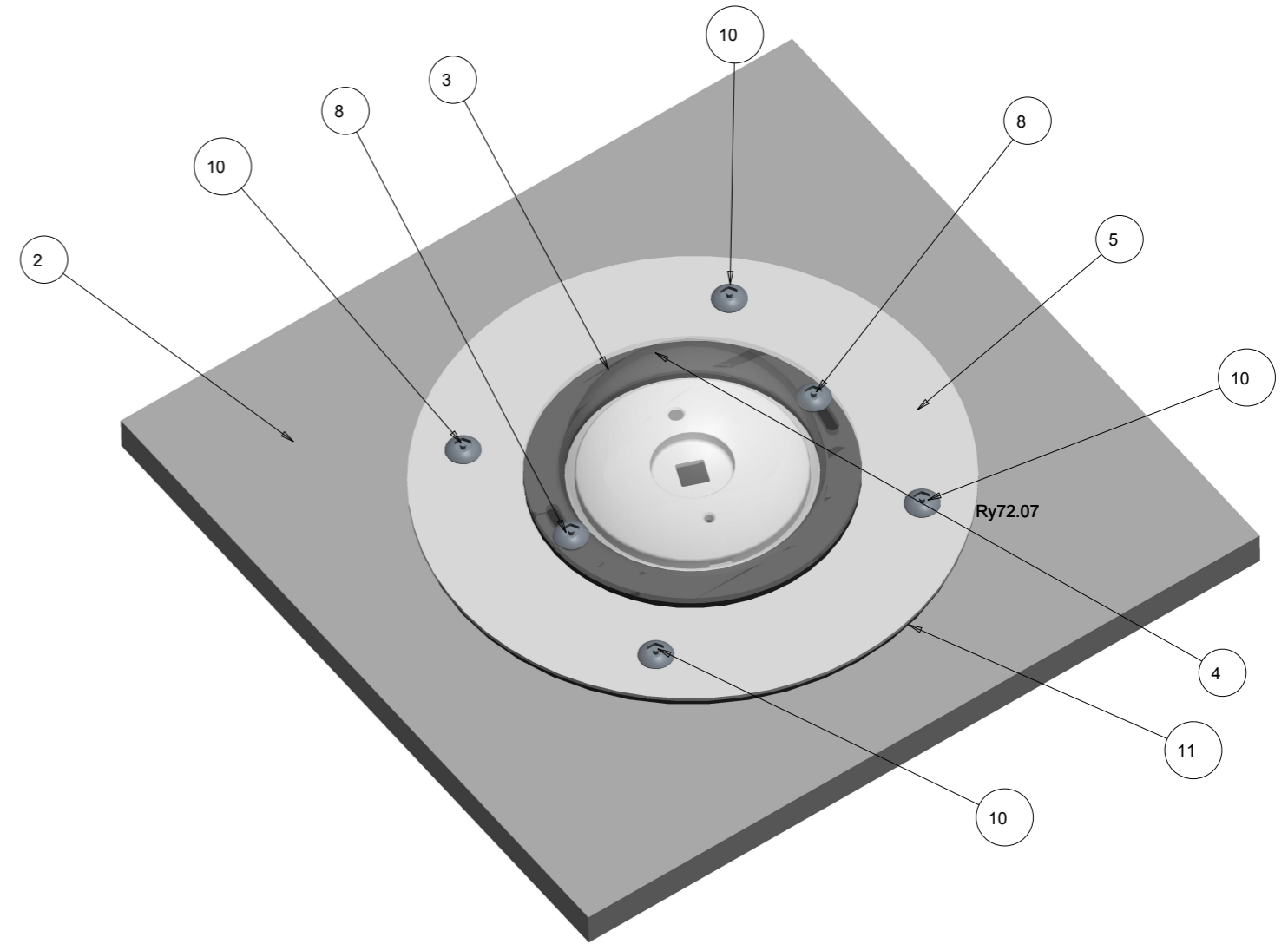
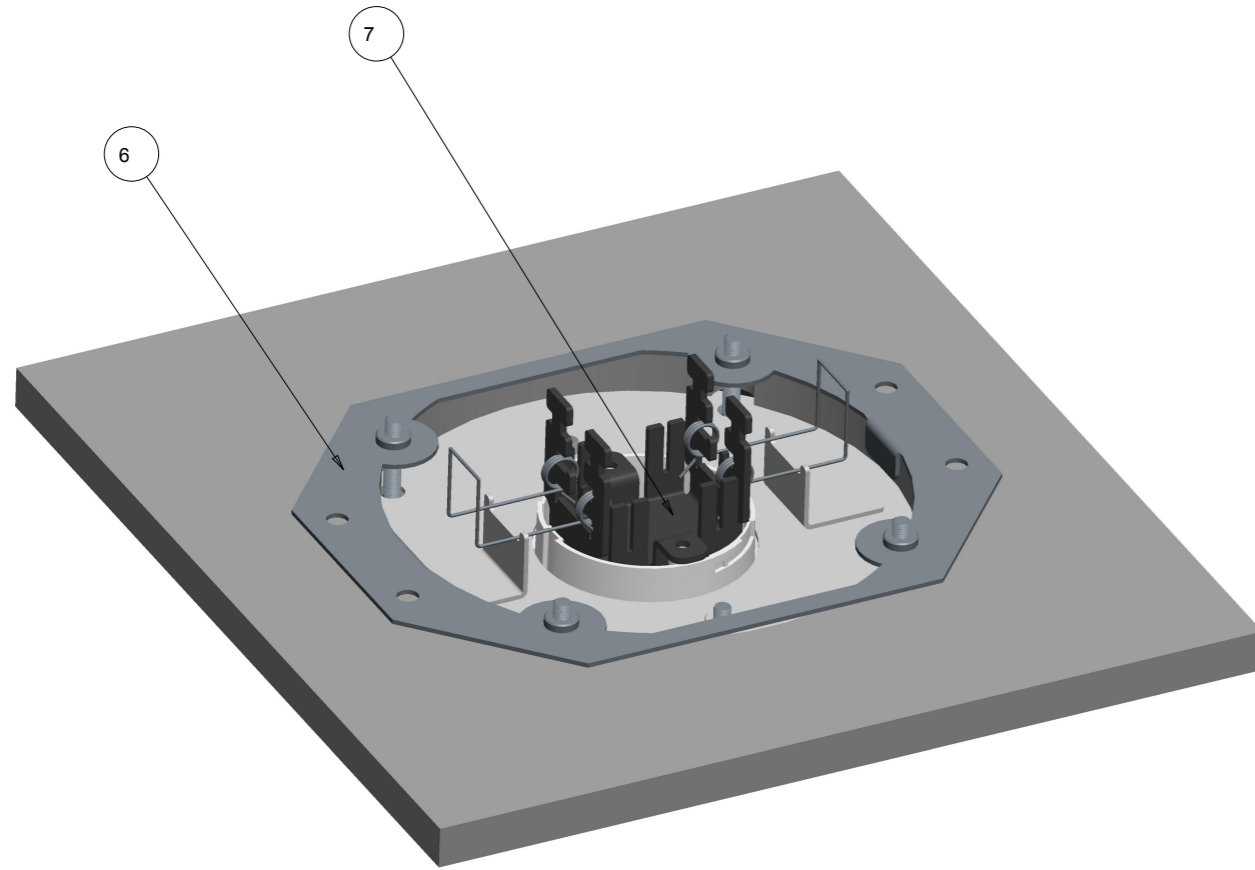

11	21-MPMD834	VP SF OUTER GASKET	1
10	22-00061	M4X30 SECURITY TORX PIN SCREW	4
9	24-00085	M4 FLAT NYLON WASHER	4
8	22-00060	M3X10 SECURITY TORX PIN SCREW	2
7	02-SFLED1	LED SPITFIRE ASSEMBLY(REFERENCE ONLY)	1
6	26-MPMD806	LED S/FIRE VANDAL TOP PLATE	1
5	26-MPMA364	LED S/FIRE VANDAL FACE PLATE	1
4	21-MPMD362	GASKET SF HEAD	1
3	CSMD004	CLEAR SMALL HEAD DOME PERSPEX	1
2	-	CEILING(REFERENCE ONLY)	1
1	30-00135	CARTON BOX	1
ITEM	PART #	DESCRIPTION	QTY

APPROVED: JMc	TOLERANCES
DATE APPROVED: 29/7/11	LINEAR ±0.50
	HOLE CENTRES ±0.20
	HOLE DIAMETERS ±0.10
	ANGULAR ±0.5°
3RD ANGLE PROJECTION	ALL HOLE DIAMETERS STATED ARE FINISHED SIZES AFTER PLATING (IF APPLICABLE)

Thomas & Betts Australasia Pty Ltd 23A Nyrang Street, Lidcombe NSW 2141 Australia www.tnbaust.com
DRAWN BY : MMu DATE : 16-Mar-11

WP SPITFIRE VANDAL PROOF		
MPMA372		
SCALE : 0.600	SHEET : 1 OF 3	SIZE : A3

P/No: SFLEDVRWR-KIT

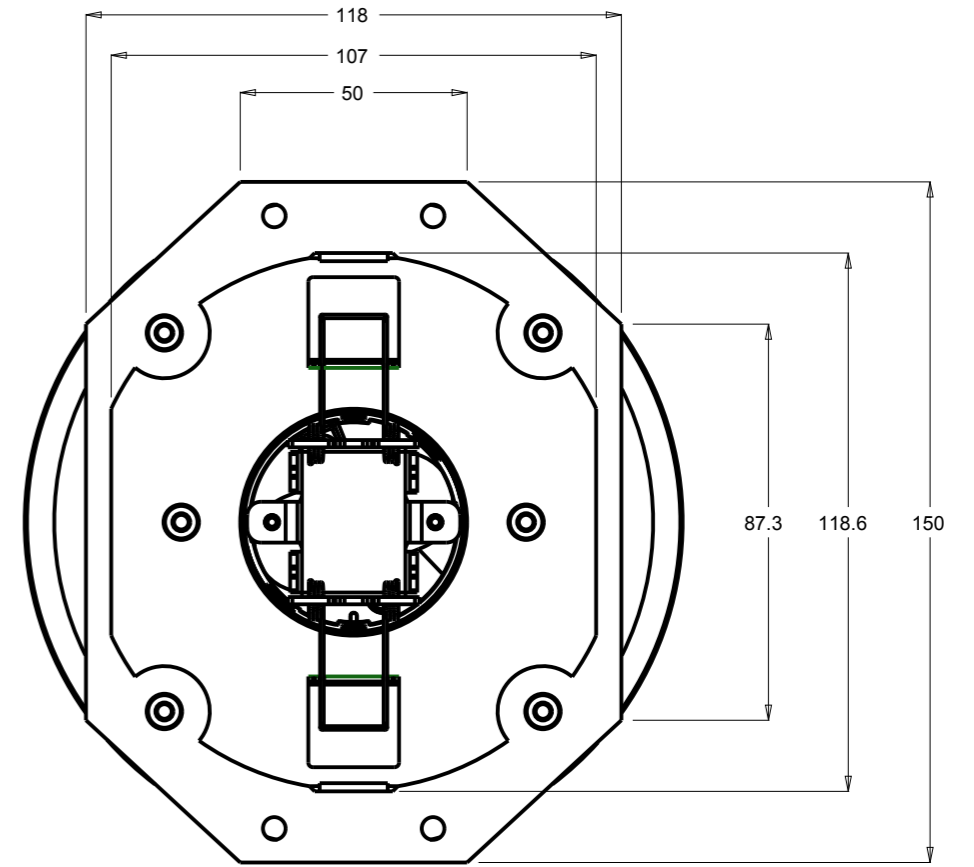
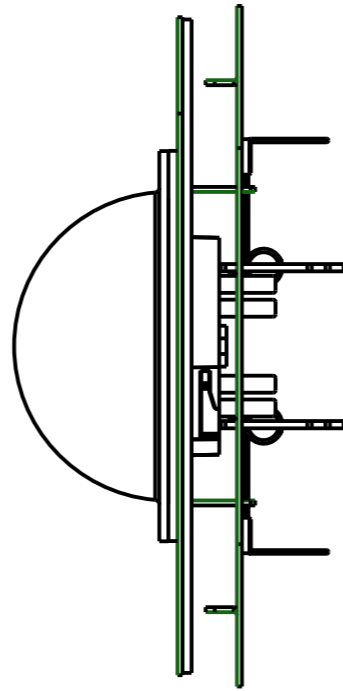
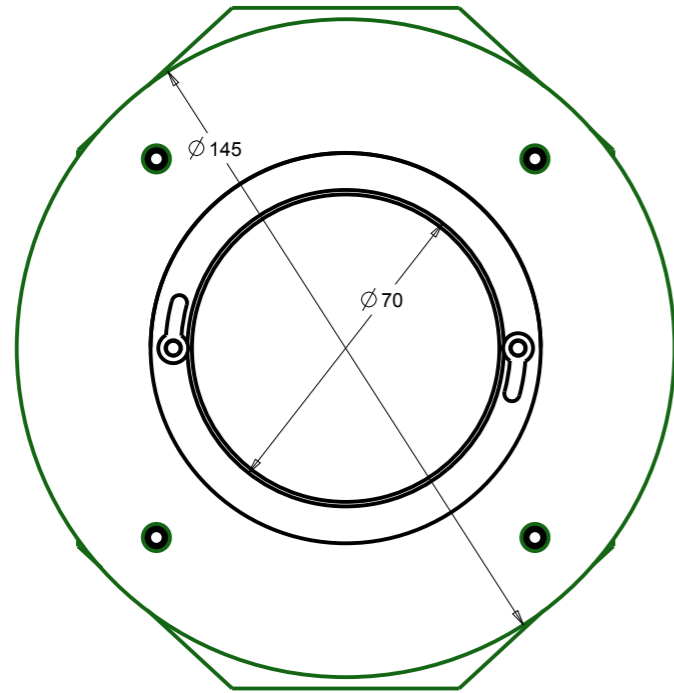
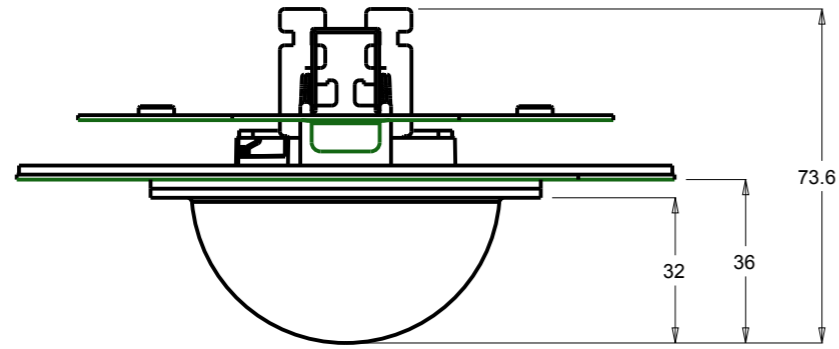

APPROVED	TOLERANCES			WP SPITFIRE VANDAL PROOF	
	LINEAR	±0.50			
DATE APPROVED	HOLE CENTRES	±0.20			
	HOLE DIAMETERS	±0.10			
	ANGULAR	±0.5°			
3RD ANGLE PROJECTION	ALL HOLE DIAMETERS STATED ARE FINISHED SIZES AFTER PLATING (IF APPLICABLE)		Thomas & Betts Australasia Pty Ltd 23A Nyrang Street, Lidcombe NSW 2141 Australia www.tnbaust.com		MPMA372
			DRAWN BY : MMu DATE : 06-Jul-11	SCALE : 0.600	SHEET : 2 OF 3
					SIZE : A3

# INSTALLATION PROCESS

STEP 1  
ATTACHED SPITFIRE TO FACEPLATE  
USING SPRING SUPPLIED ON SPITFIRE

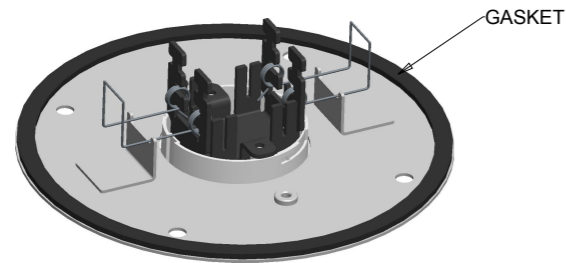

STEP 2  
CUT A  $\varnothing$  120mm HOLE IN THE CIELING  
USING THE PROVIDED TEMPLATE, MARK LOCATIONS  
OF HALF ROUNDS AND USE ROUND FILE OR SIMILAR  
TO CUT TO THE TEMPLATE SHAPE

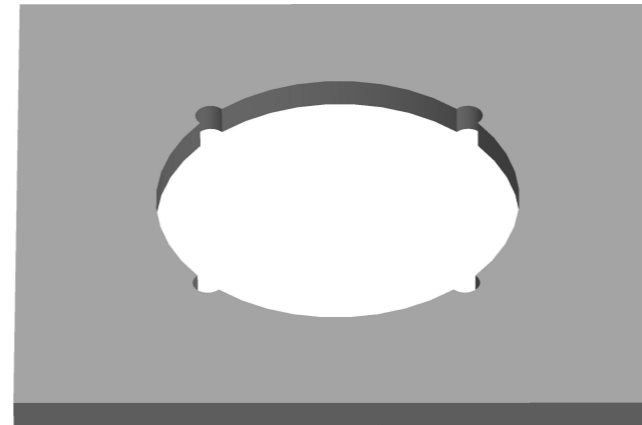

STEP 3  
POKE THE TOP PLATE THROUGH THE  
CEILING HOLE AND LOCATE OVER HOLE - TABS  
ON PLATE ASSIST IN THIS PROCESS

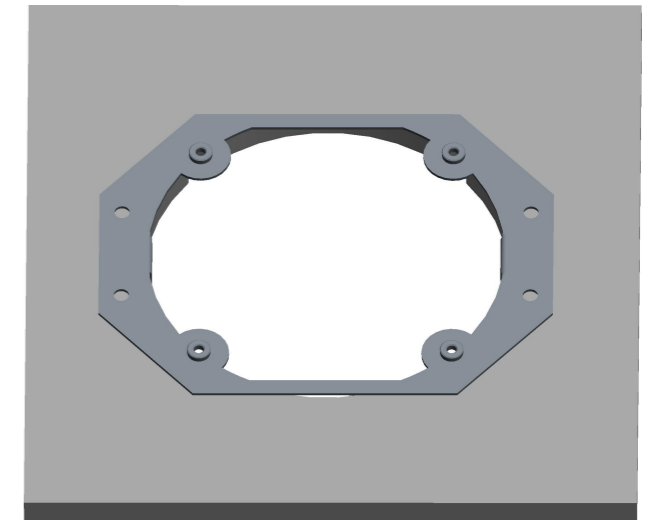

STEP 4  
ATTACHED FACE PLATE TO TOP PLATE  
USING 4x M4 SECURITY SCREWS

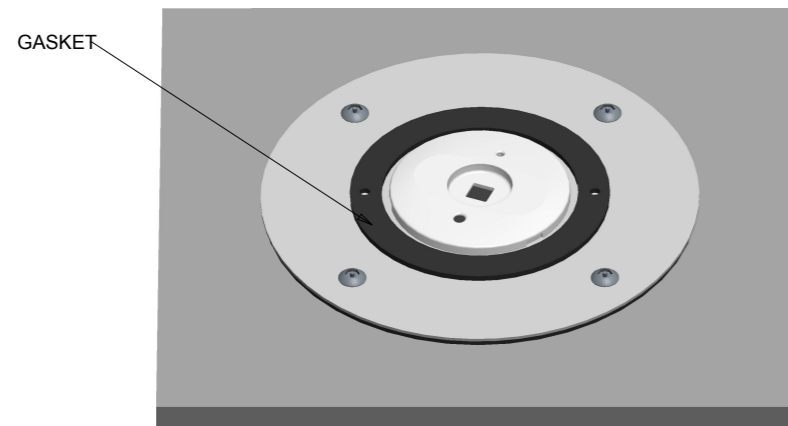

STEP 5  
ATTACHED DOME TO FACE PLATE  
USING 2x M4 SECURITY SCREWS

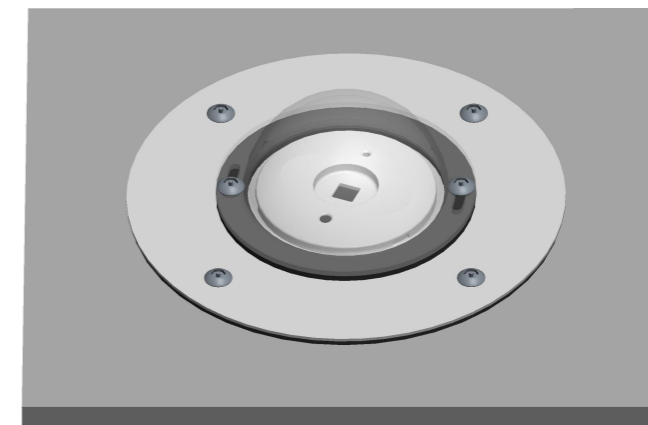

APPROVED	TOLERANCES			WP SPITFIRE VANDAL PROOF	
	LINEAR	±0.50			
DATE APPROVED	HOLE CENTRES	±0.20			
	HOLE DIAMETERS	±0.10			
	ANGULAR	±0.5°			
3RD ANGLE PROJECTION	ALL HOLE DIAMETERS STATED ARE FINISHED SIZES AFTER PLATING (IF APPLICABLE)	Thomas & Betts Australasia Pty Ltd 23A Nyrang Street, Lidcombe NSW 2141 Australia www.tnbaust.com		MPMA372	
		DRAWN BY : MMu DATE : 16-Mar-11		SCALE : 0.400	SHEET : 3 OF 3
					SIZE : A3